

Reg. No. :

--	--	--	--	--	--	--	--	--	--	--	--	--	--	--	--	--	--	--	--

**Question Paper Code : 30139**

B.E./B.Tech. DEGREE EXAMINATIONS, APRIL/MAY 2023.

Third Semester

Electronics and Communication Engineering

EC 3353 – ELECTRONIC DEVICES AND CIRCUITS

(Common to Electronics and Telecommunication Engineering)

(Regulations 2021)

Time : Three hours

Maximum : 100 marks

Answer ALL questions.

PART A — (10 × 2 = 20 marks)

1. Define break down voltage of Zener diode.
2. Draw the symbols of Diode, Zener diode, BJT and UJT.
3. Name the factors that affect stability of Q point of a Transistor Amplifier.
4. What is the need for biasing in Transistor Amplifier?
5. Mention the purpose of Differential Amplifier.
6. Find the Q factor value of a tuned circuit with resonant frequency of 1600 kHz and bandwidth of 10 kHz.
7. Define Piezoelectric effect.
8. Name a low frequency and high frequency oscillator.
9. What is a dc to dc converter?
10. Mention the operating point and conduction angle of Class A amplifier.

PART B — (5 × 13 = 65 marks)

11. (a) Explain the working and V-I characteristics of PN junction diode and Zener diode.

Or

- (b) Explain the working of full wave bridge rectifier and derive its average voltage, RMS voltage, Peak factor, Form factor, Ripple factor and rectification efficiency.

12. (a) (i) Explain fixed bias circuit for BJT. Discuss the merits and demerits of fixed bias circuit. (7)  
 (ii) Explain the voltage divider biasing of MOSFET. (6)

Or

- (b) Derive the expression for current gain, input impedance and voltage gain of a CE Transistor Amplifier.

13. (a) Explain BJT based Cascode amplifier and state its advantages.

Or

- (b) (i) Explain the working of differential amplifier and derive the expression for CMRR. (8)  
 (ii) Why Neutralization is needed and explain Hazeltine Neutralization method? (5)

14. (a) (i) Draw the block diagram of a voltage series feedback amplifier and derive the equation for input impedance and the voltage gain. (8)  
 (ii) Explain Nyquist criterion to analyze the stability of feedback amplifiers. (5)

Or

- (b) (i) Derive the expression for the frequency of oscillation and the minimum gain required for sustained oscillation of the RC phase shift oscillator. Also list the merits and demerits of the RC phase shift oscillator. (10)  
 (ii) Discuss the factors that contribute to change in frequency of oscillations. (3)

15. (a) With neat circuit diagram, derive the expression for output voltage of a buck-boost converter.

Or

- (b) With neat circuit diagram, explain the working of class AB power amplifier using MOSFET and state the advantages of using MOSFET over BJT.

PART C — (1 × 15 = 15 marks)

16. (a) (i) A voltage series negative feedback amplifier has a voltage gain without feedback  $A = 500$ , input resistance  $R_i = 3 \text{ K}\Omega$ , output resistance  $R_o = 20 \text{ K}\Omega$  and feedback ratio  $\beta = 0.01$ . Calculate the voltage gain  $A_f$  input resistance  $R_{if}$  and output resistance  $R_{of}$  of the amplifier with feedback. (6)  
 (ii) For the differential amplifier circuit shown in Fig. 16(a), assume  $\beta$  of both the transistors is very high. Find the value of  $V_{in2}$  for which current flowing through  $2 \text{ k}\Omega$  resistor of transistor  $Q_2$  is  $1.8 \text{ mA}$ . Assume thermal voltage  $V_T = 26 \text{ mV}$ . (9)

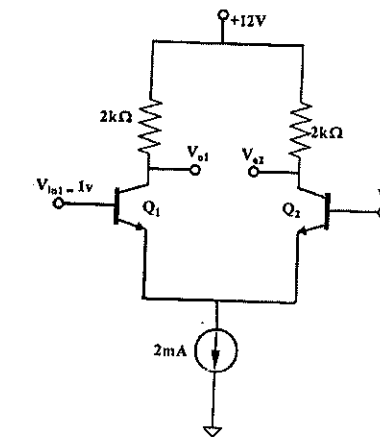

Fig. 16(a)

Or

- (b) In a Colpitts oscillator, the values of the inductors and capacitors in the tank circuit are  $L = 40 \text{ mH}$ ,  $C_1 = 100 \text{ pF}$  and  $C_2 = 500 \text{ pF}$   
 (i) Find the frequency of oscillations.  
 (ii) If the output voltage is  $10 \text{ V}$ , find the feedback voltage.  
 (iii) Find the minimum gain, if the frequency is changed by changing  $L$  alone  
 (iv) Find the value of  $C_1$  for a gain of 10.  
 (v) Also, find the new frequency. (15)