

Reg. No. : 

--	--	--	--	--	--	--	--	--	--	--	--

**Question Paper Code : 50541**

B.E./B.Tech. DEGREE EXAMINATIONS, APRIL/MAY 2024.

Fifth Semester

Civil Engineering

CE 3502 – STRUCTURAL ANALYSIS – I

(Regulations 2021)

Time : Three hours

Maximum : 100 marks

Answer ALL questions.

PART A — (10 × 2 = 20 marks)

1. What are the assumptions made in the analysis of pin-jointed trusses?
2. What is the effect of temperature on the members of a statically determinate plane truss?
3. List out the limitations of the slope deflection method.
4. Distinguish symmetric and skew-symmetric loadings in the symmetrical frames.
5. Define the term “Carry-over factor” in the moment distribution method.
6. Mention the conditions under which side sway occurs in the portal frames.
7. What is meant by compatibility conditions used in the flexibility method?
8. What is called a primary structure? Give examples.
9. State the properties of the stiffness matrix.
10. Write down the equation of the element stiffness matrix as applied to the 2D plane element.

11. (a) The pin-jointed 2D truss is loaded with a horizontal force of 15 kN at joint S and another 15 kN vertical force at joint U as shown in Fig. Q11 (a). Find the forces in the members RS, SU and VP (in kN), taking tension as positive and compression as negative.

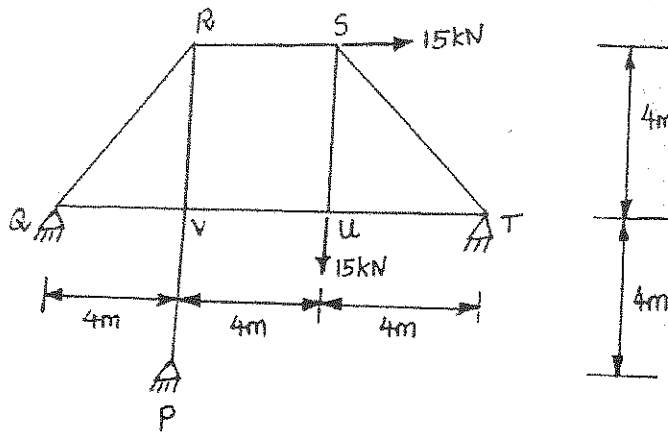

Fig. Q11 (a)

Or

- (b) Determine the vertical deflection of point D in the truss as shown in fig. Q11 (b). The cross sectional areas of the members AD and BE are  $1500 \text{ mm}^2$  while those of the other members are  $1000 \text{ mm}^2$ . Take  $E = 200 \text{ kN/mm}^2$ .

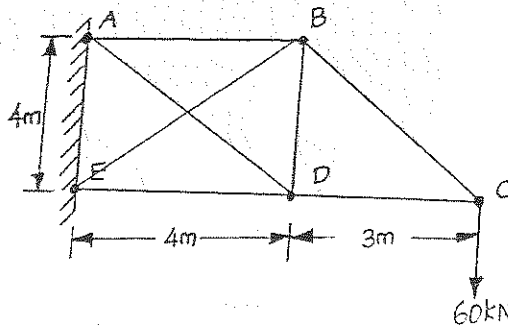

Fig. Q11 (b)

12. (a) Analyse the continuous beam ABC shown in Fig. Q12(a) by slope deflection method, if the support B sinks by 15 mm. Draw the bending moment diagram. Assume  $E = 200 \times 10^6 \text{ kN/m}^2$  and  $I = 70 \times 10^6 \text{ mm}^4$ .

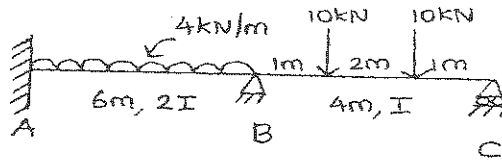

Fig. Q12 (a)

Or

- (b) Analyse the frame shown in Fig. Q12(b) using slope deflection method and determine the slope at points B and C. Draw the bending moment diagram.

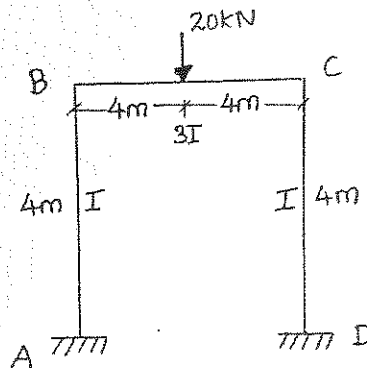

Fig. Q12 (b)

13. (a) Determine the end moments for the frame shown in Fig. Q13(a) using moment distribution method.

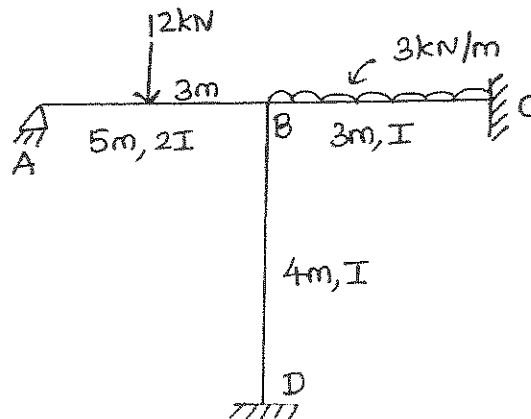

Fig. Q13 (a)

Or

- (b) Analyze the continuous beam ABCD (Fig. Q.13(b)) using moment distribution method and draw the shear force diagram.

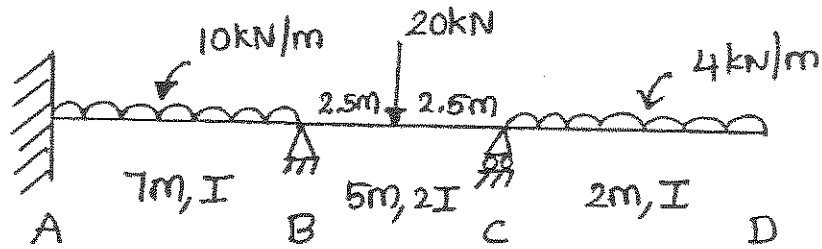

Fig. Q13 (b)

14. (a) Analyze the rigid frame shown in the Fig. Q14(a), by flexibility matrix method.

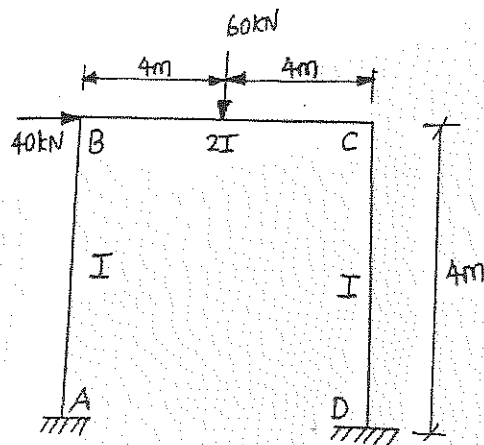

Fig. Q14 (a)

Or

- (b) Analyze the continuous beam ABC shown in the Fig Q14 (b), by flexibility matrix method. Take  $EI = \text{Constant}$ .

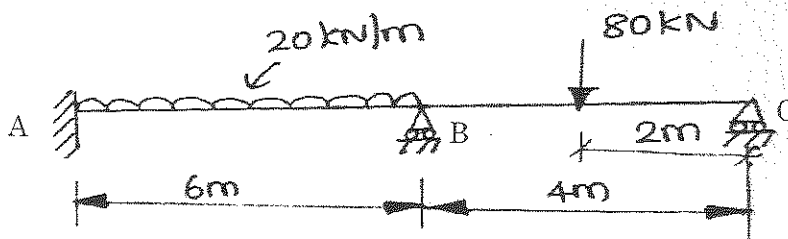

Fig. Q14 (b)

15. (a) Find the forces in all the members of pin jointed frame PQRS shown in Fig Q15 (a), using stiffness method. Assume Area =  $1800 \text{ mm}^2$  and Young's modulus =  $200 \text{ GPa}$  for all the members.

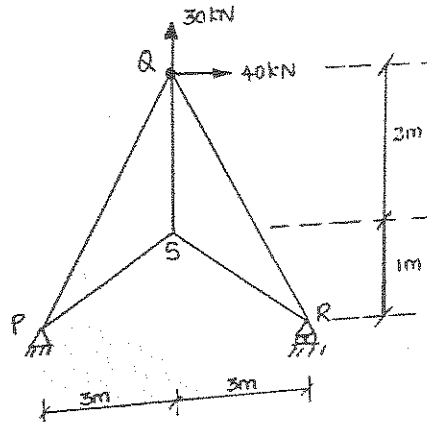

Fig. Q15 (a)

Or

- (b) Analyze the continuous beam shown in the Fig. Q15 (b) using the stiffness method. Draw the bending moment diagram.

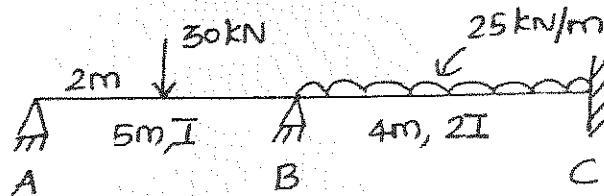

Fig. Q15 (b)

PART C — (1 × 15 = 15 marks)

16. (a) Determine the vertical displacement of joint E of truss shown in Fig. Q16 (a) due to given loading and due to member BE and CE being  $10 \text{ mm}$  too long. Given, for all members cross sectional area =  $1000 \text{ mm}^2$ , Young's modulus =  $200 \text{ kN/mm}^2$ .

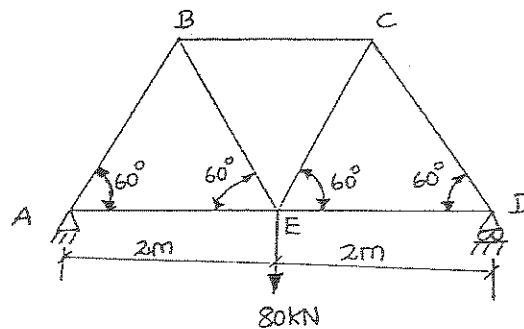

Fig. Q16 (a)

Or

- (b) Analyze the frame shown in the Fig. Q16 (b) using the moment distribution method and draw the Bending moment diagram.

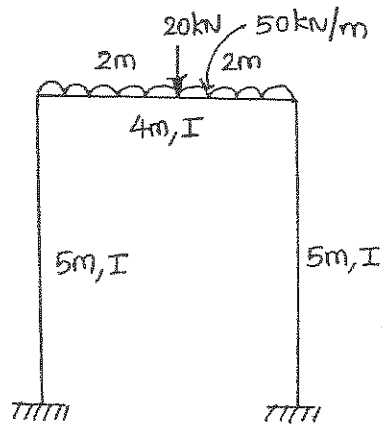

Fig. Q16 (b)