

Reg. No. :

--	--	--	--	--	--	--	--	--	--	--	--	--	--	--	--	--	--	--	--

Question Paper Code : 51336

B.E./B.Tech. DEGREE EXAMINATIONS, APRIL/MAY 2024.

Third Semester

Mechanical Engineering

ME 3351 — ENGINEERING MECHANICS

(Common to Automobile Engineering/Civil Engineering/Industrial Engineering/Industrial Engineering and Management/Materials science and Engineering/Mechanical Engineering (Sandwich)/ Mechanical and Automation Engineering/Mechatronics Engineering/Production Engineering/Robotics and Automation/Safety and Fire Engineering)

(Regulations 2021)

(Also Common to PTME 3351 — Engineering Mechanics for B.E. (Part-Time) Second Semester — Civil Engineering/Mechanical Engineering — Regulations 2023)

Time : Three hours

Maximum : 100 marks

Answer ALL questions.

PART A — (10 × 2 = 20 marks)

1. Define equilibrium of particles in plane.
2. The greatest and least resultants of two forces are 7 kN and 1 kN respectively. Determine the angle between the two forces when their resultant is 5 kN.
3. State Varignons theorem.
4. Differentiate between space diagram and a free body diagram.
5. What is Pappus-Guldinus theorems?
6. What is meant by radius of gyration?
7. Define coefficient of friction.

8. Extend the condition at which the angle of repose and limiting angle of friction become equal.
9. What is meant by projectile and trajectory?
10. Give the equations of motion in a straight line.

PART B — (5 × 13 = 65 marks)

11. (a) A system of four forces acting on a body is shown in figure 11(a). Determine the resultant force and its direction.

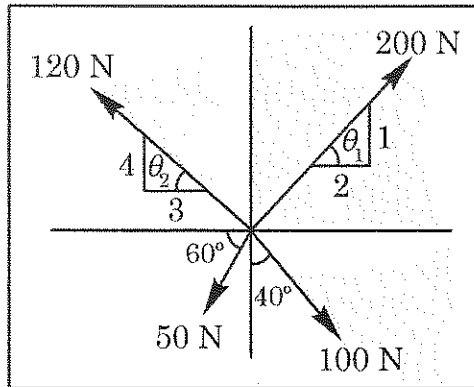

Fig. 11 (a)

Or

- (b) Two cables are tied together at C and are loaded as shown in figure 11(b). Determine the tension in (i) Cable AC and (ii) Cable BC.

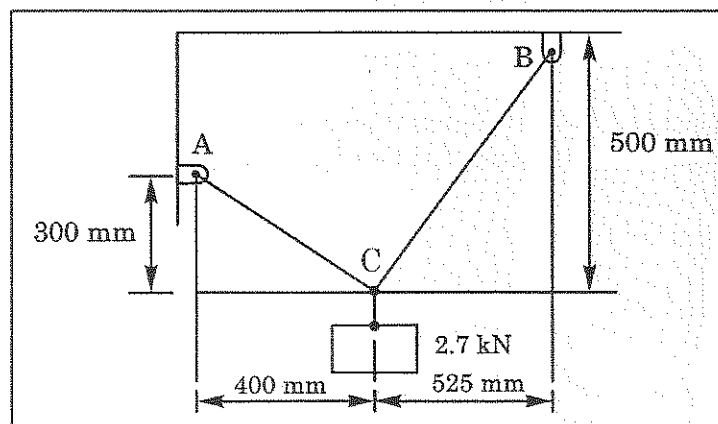

Fig. 11 (b)

12. (a) Determine the moments of a 200 N force about the two points A and B of the angle bracket (fig 12(a)).

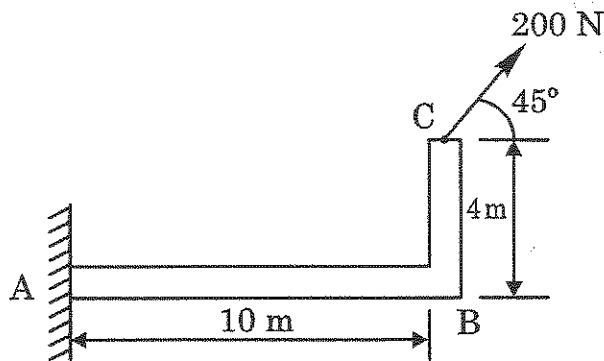

Fig. 12(a)

Or

- (b) The three forces and a couple in figure 12(b) are applied to an angle bracket

- (i) Find the resultant of this system of forces
- (ii) Locate the points where the line of action of the resultant intersects the line AC and a line BC.

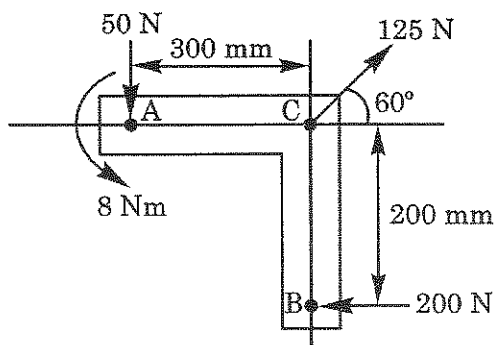

Fig. 12(b)

13. (a) Find the centroid of the Z section shown, in figure 13 (a). Also determine the first moments of the area about x and y axes. All the dimensions are in mm.

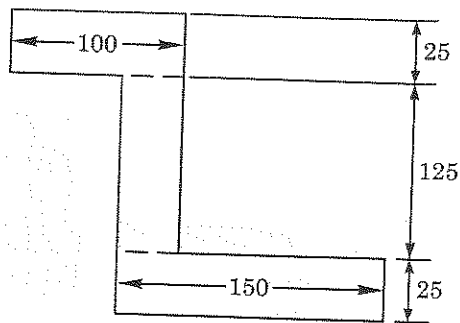

Fig. 13 (a)

Or

- (b) Find the moment of inertia of T-section about XX-axis passing through its centroid as shown in figure 13 (b). All the dimensions are in mm.

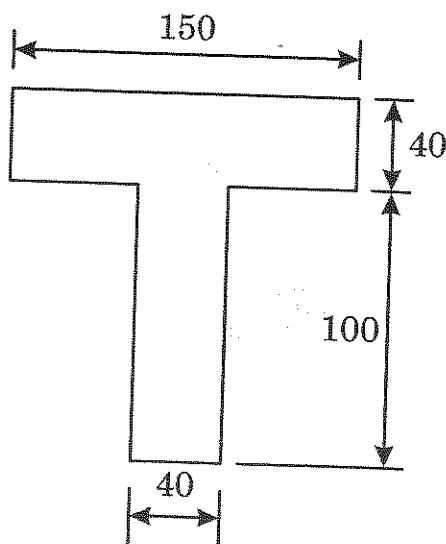

Fig. 13 (b)

14. (a) A body of weight 2 kN kept on an inclined plane is acted upon by a 0.75 kN as shown in figure 14 (a). The coefficients of friction between the block and the plane are $\mu_s=0.30$ and $\mu_k=0.25$. Check whether the block remains in equilibrium or not.

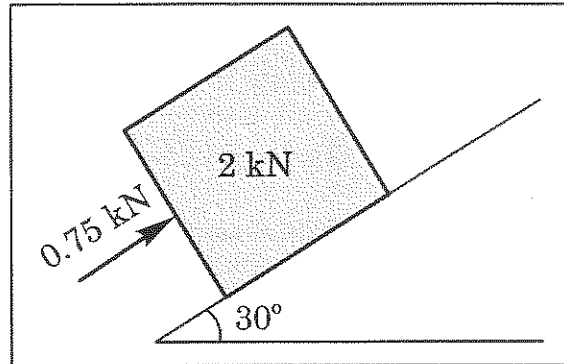

Fig. 14 (a)

Or

- (b) Two blocks of weight 500 N and 900 N connected by a rod and kept on an inclined plane as shown in figure 14 (b). The rod is parallel to the plane. The coefficient of friction between 500 N block and the plane is 0.3 and that between 900 N and the plane is 0.4. Find the inclination of the plane with the horizontal when the motion down the plane is just about to start.

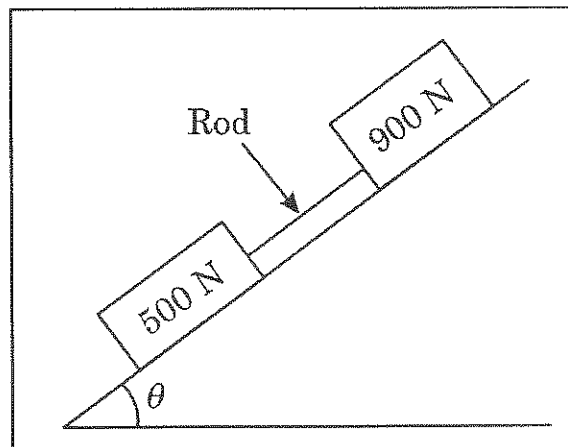

Fig. 14 (b)

15. (a) A car covers a distance of 30 m in 3 s and 70 m in 5 s. Find the initial velocity of car and acceleration assuming it uniform.

Or

- (b) A projectile is thrown with a velocity of 5 m/s at an elevation of 60° to the horizontal. Find the velocity of another projectile thrown at an elevation of 45° which will have (i) equal horizontal distance, (ii) equal maximum height and equal time of flight with first.

PART C — (1 × 15 = 15 marks)

16. (a) A external brake band assembly is shown in figure 16 (a). The coefficient of static friction between the flat belt and the drum is 0.28. Determine the minimum force P necessary to prevent the drum from rotating when subjected to a counter clockwise torque of 125 N-m.

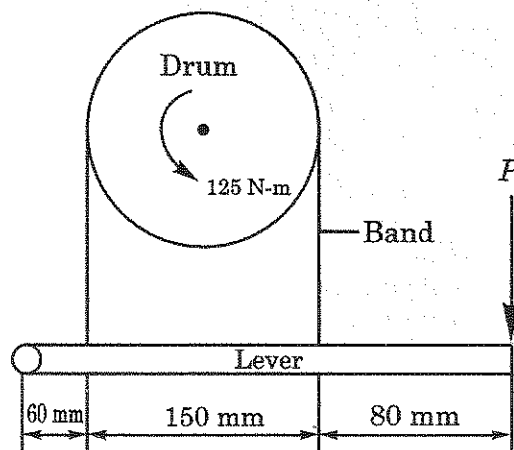

Fig. 16 (a)

Or

- (b) A gun fires a bullet at the rate of 200 m/s penetrates a wooden panel to a depth of 50 cm. If the bullet with the same velocity penetrates a wooden panel of 25 cm thick, with what velocity would it emerge? Take the resistance offered by the wood to be uniform in both the cases.