

Reg. No. :

--	--	--	--	--	--	--	--	--	--	--	--	--	--	--	--	--	--	--	--

Question Paper Code : 51344

B.E./B.Tech. DEGREE EXAMINATIONS, APRIL/MAY 2024.

Fifth Semester

Mechanical Engineering

ME 3591 — DESIGN OF MACHINE ELEMENTS

(Regulations 2021)

Time : Three hours

Maximum : 100 marks

(Use of PSG Design data book is permitted)

Answer ALL questions.

PART A — (10 × 2 = 20 marks)

1. Distinguish between design synthesis and design analysis.
2. Give any two examples of mechanical components that fail by elastic deflection.
3. What are the disadvantages of hollow shaft over solid shaft?
4. What is coupling? Where do you use it?
5. Where do you use a knuckle joint? Give two practical examples.
6. What are the advantages of welded joints compared with riveted joints?
7. What is stiffness of spring?
8. What are the applications of flywheel?
9. Why are ball and roller bearings called 'antifriction' bearings?
10. What are the primary functions of oil seal?

PART B — (5 × 13 = 65 marks)

11. (a) The dimensions of an overhang crank are given in Fig.1. The force P acting at the crankpin is 1 kN. The crank is made of steel 30C8 ($S_{yt} = 400 \text{ N/mm}^2$) and the factor of safety is 2. Using maximum shear stress theory of failure, determine the diameter d at the section - XX.

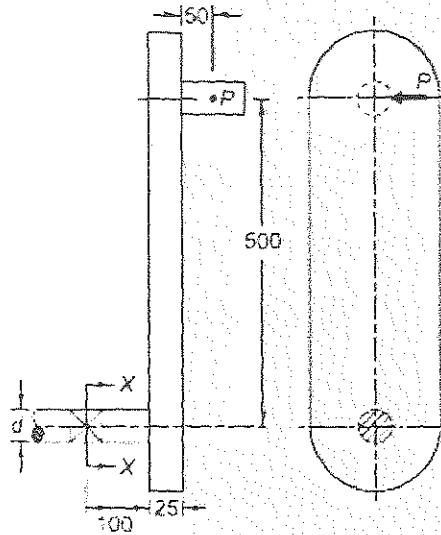

All dimensions are in mm

Figure - 1 Overhang Crank

Or

- (b) A component machined from a plate made of steel 45C8 ($S_{ut} = 630 \text{ N/mm}^2$) is shown in Fig.2. It is subjected to a completely reversed axial force of 50 kN. The expected reliability is 90% and the factor of safety is 2. The size factor is 0.85. Determine the plate thickness t for infinite life if the notch sensitivity factor is 0.8.

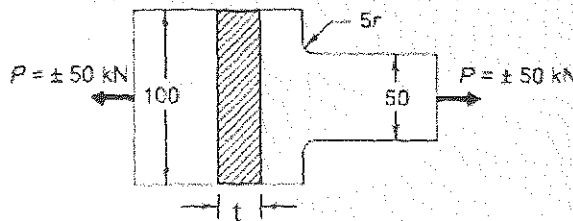

All dimensions are in mm

Figure - 2

12. (a) It is required to design a square key for fixing a gear on a shaft of 25 mm diameter. The shaft is transmitting 15 kW power at 720 rpm to the gear. The key is made of steel 50C4 ($S_{yt} = 460 \text{ N/mm}^2$) and the factor of safety is 3. For key material, the yield strength in compression can be assumed to be equal to the yield strength in tension. Determine the dimensions of the key.

Or

- (b) Design a muff coupling to connect two steel shafts transmitting 25 kW power at 360 rpm. The shafts and key are made of plain carbon steel 30C8 ($S_{yt} = S_{yc} = 400 \text{ N/mm}^2$). The sleeve is made of grey cast iron FG 200 ($S_{ut} = 200 \text{ N/mm}^2$). The factor of safety for the shafts and key is 4. For the sleeve, the factor of safety is 6 based on ultimate strength.
13. (a) A double-threaded power screw, with ISO metric trapezoidal threads is used to raise a load of 300 kN. The nominal diameter is 100 mm, and the pitch is 12 mm. The coefficient of friction at the screw threads is 0.15. Neglecting collar friction,

Calculate

- (i) torque required to raise the load;
(ii) torque required to lower the load; and
(iii) efficiency of the screw.

Or

- (b) A beam of rectangular cross section is welded to a support by means of fillet welds as shown in Fig.3. Determine the size of the welds, if the permissible shear stress in the weld is limited to 75 N/mm^2 .

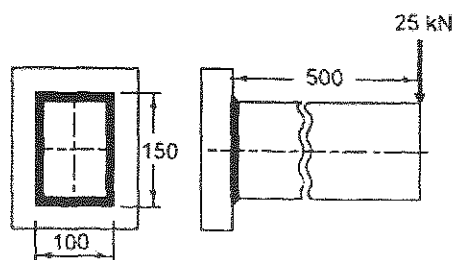

All dimensions are in mm

Figure - 3

14. (a) It is required to design a helical compression spring subjected to a maximum force of 1250 N. The deflection of the spring corresponding to the maximum force should be approximately 30 mm. The spring index can be taken as 6. The spring is made of patented and cold-drawn steel wire. The ultimate tensile strength and modulus of rigidity of the spring material are 1090 and 81370 N/mm² respectively. The permissible shear stress for the spring wire should be taken as 50% of the ultimate tensile strength.

Design the spring and calculate:

- (i) wire diameter.
- (ii) mean coil diameter.
- (iii) number of active coils.
- (iv) total number of coils.
- (v) free length of the spring; and
- (vi) pitch of the coil.

Draw a neat sketch of the spring showing various dimensions.

Or

- (b) A machine is driven by a motor, which exerts a constant torque. The resisting torque of the machine increases uniformly from 500 N-m to 1500 N-m through a 360° rotation of the driving shaft and drops suddenly to 500 N-m again at the beginning of the next revolution. The mean angular velocity of the machine is 30 rad/s and the coefficient of speed fluctuations is 0.2. A solid circular steel disk, 25 mm thick, is used as flywheel. The mass density of steel is 7800 kg/m³ while Poisson's ratio is 0.3. Calculate the outer radius of the flywheel disk and the maximum stresses induced in it.
15. (a) A single-row deep groove ball bearing is subjected to a radial force of 8 kN and a thrust force of 3 kN. The shaft rotates at 1200 rpm. The expected life L_{10h} of the bearing is 20000 h. The minimum acceptable diameter of the shaft is 75 mm. Select a suitable ball bearing for this application.

Or

(b) The following data is given for a 360° hydrodynamic bearing :

Radial load = 3.2 kN

Journal speed = 1490 rpm

Journal diameter = 50 mm

Bearing length = 50 mm

Radial clearance = 0.05 mm

Viscosity of lubricant = 25 cP

Assuming that the total heat generated in the bearing is carried by the total oil flow in the bearing, calculate

- (i) coefficient of friction;
- (ii) power lost in friction;
- (iii) minimum oil film thickness;
- (iv) flow requirement in 1 litres/min; and
- (v) temperature rise.

PART C — (1 × 15 = 15 marks)

16. (a) A line shaft supporting two pulleys A and B is shown in Fig.4. Power is supplied to the shaft by means of a vertical belt on the pulley A, which is then transmitted to the pulley B carrying a horizontal belt. The ratio of belt tension on tight and loose sides is 3:1. The limiting value of tension in the belts is 2.7 kN. The shaft is made of plain carbon steel 40C8 ($S_{ut} = 650 \text{ N/mm}^2$ and $S_{yt} = 380 \text{ N/mm}^2$). The pulleys are keyed to the shaft. Determine the diameter of the shaft according to the ASME code if, $k_b = 1.5$ and $k_t = 1.0$

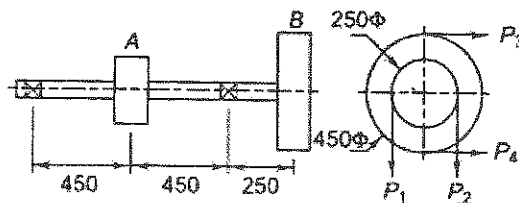

All dimensions are in mm

Figure -4

Or

- (b) Two rods, made of plain carbon steel 40C8 ($S_{yt} = 380 \text{ N/mm}^2$), are to be connected by means of a cotter joint. The diameter of each rod is 50 mm and the cotter is made from a steel plate of 15 mm thickness. Calculate the dimensions of the socket end making the following assumptions:
- (i) The yield strength in compression is twice that of the tensile yield strength; and
 - (ii) The yield strength in shear is 50% of the tensile yield strength. The factor of safety is 6.