

Reg. No. :

--	--	--	--	--	--	--	--	--	--	--	--	--	--	--	--	--	--	--	--

**Question Paper Code : 20924**

B.E./B.Tech. DEGREE EXAMINATIONS, NOVEMBER/DECEMBER 2023.

Third Semester

Electronics and Communication Engineering

EC 3351 – CONTROL SYSTEMS

(Common to Electronics and Telecommunication Engineering)

(Use of Semi-log graph and Polar graph and Normal graph sheet is permitted)

(Regulations 2021)

Time : Three hours

Maximum : 100 marks

Answer ALL questions.

PART A — (10 × 2 = 20 marks)

1. Define transfer function of a system.
2. Write Mason's Gain formula.
3. What is the significance of integral mode in a PID controller?
4. List the time domain specifications of second order system.
5. Define Gain Margin.
6. When lag-lead compensator is required?
7. Define BIBO stability.
8. State Routh-Hurwitz criterion for stability.
9. What is state variable?
10. Define Controllability and Observability.

PART B — (5 × 13 = 65 marks)

11. (a) Derive the transfer function of armature controlled DC servo motor system. (13)

Or

- (b) Using block diagram reduction technique, obtain the closed loop transfer function for the following system. (13)

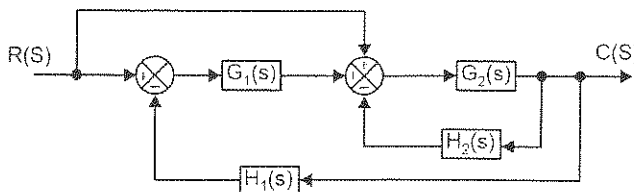

12. (a) (i) The open loop transfer function of the mechanical system is given by  $G(s) = \frac{10(s+2)}{s(s+1)(s+3)}$ . Find the type of input signal that will provide rise to a constant steady state error and calculate its values. (7)
- (ii) Discuss about PI controller with suitable electronic circuit and derive its transfer function. (6)

Or

- (b) The open loop transfer function of a unity feedback system is given by  $G(s) = \frac{25}{s(s+5)}$ . Obtain the rise time, peak time and settling time when the system is subjected to unit step input. (13)

13. (a) The open loop transfer function of the system,  $G(s) = \frac{1}{s(4s+1)(0.5s+1)}$ . Sketch the polar plot and obtain the value of gain margin and phase margin. (13)

Or

- (b) Derive the frequency domain specifications of second order system. (13)

14. (a) (i) The open loop transfer function of feedback control system is given by  $G(s) = \frac{K}{(s^2 + 6s + 25)(s^2 + 6s + 8)}$ . Using Routh criterion, determine the range of K and frequency of oscillation of the system. (8)
- (ii) Discuss in detail about relative stability in control systems. (5)

Or

- (b) Sketch the root locus plot for the unity feedback system whose open loop transfer function is given by  $G(s) = \frac{K}{s(s^2 + 6s + 1)}$ . (13)

15. (a) (i) Determine the canonical state model of the system whose transfer function given as  $\frac{Y(s)}{U(s)} = \frac{2s+10}{(s+2)(s+3)(s+4)}$ . (7)
- (ii) A linear time invariant system is described by the following state model. (6)

$$\begin{bmatrix} \dot{x}_1 \\ \dot{x}_2 \end{bmatrix} = \begin{bmatrix} 1 & 0 \\ 1 & 1 \end{bmatrix} \begin{bmatrix} x_1 \\ x_2 \end{bmatrix} \text{ and Initial state vector, } X_0 = \begin{bmatrix} 1 \\ 0 \end{bmatrix}$$

Compute the solution of homogeneous state equation.

Or

- (b) Construct the state model of the give mechanical system. (13)

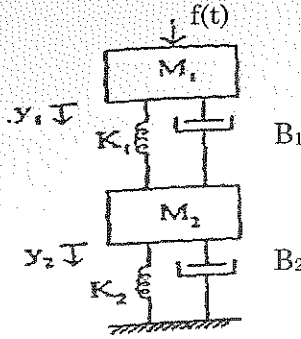

PART C — (1 × 15 = 15 marks)

16. (a) (i) Derive the solutions of Homogeneous state equations. (9)  
 (ii) Determine the state controllability of the following system. (6)

$$\begin{bmatrix} \dot{x}_1 \\ \dot{x}_2 \\ \dot{x}_3 \end{bmatrix} = \begin{bmatrix} 0 & 0 & 1 \\ -2 & -3 & 0 \\ 0 & 2 & 3 \end{bmatrix} \begin{bmatrix} x_1 \\ x_2 \\ x_3 \end{bmatrix} + \begin{bmatrix} 0 \\ 2 \\ 0 \end{bmatrix} u \text{ and } y = [1 \ 0 \ 0] \begin{bmatrix} x_1 \\ x_2 \\ x_3 \end{bmatrix}$$

Or

- (b) A unity feedback system has an open loop transfer function,  
 $G(s) = \frac{K}{s(s+1)}$ . Design a suitable phase lead compensator to satisfy the following specifications.
- The phase margin of the system is  $\geq 45^\circ$
  - Steady state error for a unit input  $\leq 1/15$
  - The gain crossover frequency of the system must be less than 7 rad/sec. (15)