

Reg. No. :

--	--	--	--	--	--	--	--	--	--	--	--	--	--	--	--	--	--	--	--

Question Paper Code : 20982

B.E./B.Tech. DEGREE EXAMINATIONS, NOVEMBER/DECEMBER 2023.

Fifth Semester

Electrical and Electronics Engineering

EE 3501 — POWER SYSTEM ANALYSIS

(Regulations 2021)

Time : Three hours

Maximum : 100 marks

Answer ALL questions.

PART A — (10 × 2 = 20 marks)

1. Draw the symbol of air circuit breaker and power circuit breaker in power system.
2. Summarize the properties of tree of a graph.
3. Outline the elements of Jacobian matrix.
4. When the PV bus is treated as PQ bus in power flow study?
5. List out the differences in representing the power system for load flow and short circuit studies.
6. Highlight the significance of sub transient reactance and transient reactance in short circuit studies.
7. Compare sequence component currents in different faults.
8. Why prefault current is not considered for unsymmetrical fault analysis?
9. How to improve the transient stability limit of power system?
10. Define critical clearing angle.

PART B — (5 × 13 = 65 marks)

11. (a) Obtain the bus incidence matrix and bus admittance matrix for the following network.

Element Number	Self		Mutual	
	Bus Code	Impedance	Bus Code	Impedance
1	1-2	0.6		
2	1-3 (1)	0.5		
3	3-4	0.3		
4	1-3 (2)	0.4	1-3 (1)	0.1
5	2-3	0.5		
6	1-4	0.2		

Or

- (b) A generator is connected to a motor through two transformers and a transmission line. The ratings of the power system components are

Generator: 25MVA, 12.4KV, 10% sub-transient reactance

Motor: 20MVA, 3.8KV, 15% Sub-transient reactance

Transformer T1: 25MVA, 11/33KV, 8% sub-transient reactance

Transformer T2: 20MVA, 33/3.3KV, 10% sub-transient reactance

Transmission line: 20Ω reactance

Motor: 20MVA, 3.8KV, 15% sub-transient reactance

Obtain the p.u. impedance diagram of the power system.

12. (a) Develop the flow chart for load flow solution for a 4-bus system having PV bus using Newton Raphson Method.

Or

- (b) Outline the classification of buses in load flow analysis and derive the power flow equation in polar coordinates.

13. (a) Summarize the need for short circuit analysis and the assumptions made in fault calculations.

Or

(b) Determine Z_{Bus} for the below network.

Element Number	Self	Bus Code	Impedance (in p.u.)
1		1-2	$j 1.2$
2		1-4	$j 1.5$
3		2-3	$j 0.2$
4		3-4	$j 0.15$
5		2-4	$j 0.3$
6		1-3	$j 1.2$

14. (a) Derive the expression for the fault current of an unloaded generator facing line to line fault.

Or

(b) A positive negative and zero sequence components of line currents are $10 \angle 20^\circ$, $7 \angle 30^\circ$, $4 \angle 60^\circ$ amperes respectively. Determine the three line currents assuming

(i) phase sequence abc (7)

(ii) phase sequence acb (6)

15. (a) Illustrate the step-by-step procedure for multi machine stability analysis using Modified Euler's method.

Or

(b) A synchronous motor is receiving 25% of the power that it is capable of receiving from an infinite bus. If the load on the motor is doubled, calculate the maximum value of torque angle during the swinging of the motor around its new equilibrium position.

PART C — (1 × 15 = 15 marks)

16. (a) In the power system shown in Fig Q. 16 (a) three-phase fault occurs at point 'P' and the fault line was opened a little latter. Find the power output equations for the pre-fault, during fault and post fault conditions.

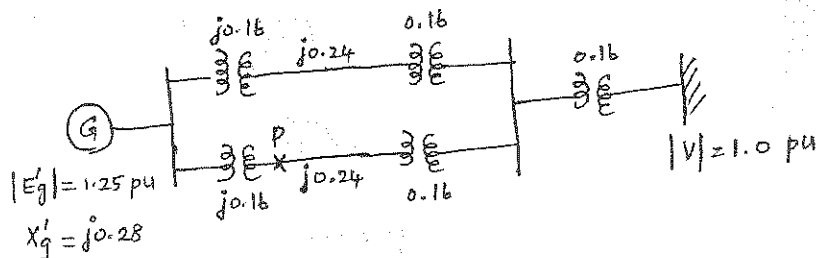

The values marked are p.u. reactance

Fig. Q 16 (a)

Or

- (b) Consider a single line diagram of a power system as shown in Fig Q. 16 (b). The generators are connected at buses 1 and 3. The magnitude of voltage at bus 1 is 1.05 p.u. The voltage magnitude at bus-3 is fixed at 1.04 p.u. with active power generation of 200MW. A load consisting of 400 MW and 250 MVAR is taken from bus-2. Line impedances are marked in p.u. on a 100 MVA base and the line-charging susceptances are neglected. Determine the voltage at buses 2 and 3 using Gauss-seidal method at the end of first iteration. Also calculate slack bus power.

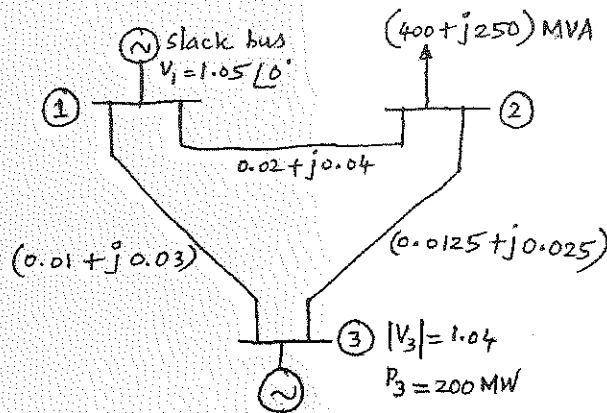

Fig. Q. 16 (b)