

Reg. No. :

Question Paper Code : 20983

B.E./B.Tech. DEGREE EXAMINATIONS, NOVEMBER/DECEMBER 2023.

Fifth Semester

Electrical and Electronics Engineering

EE 3503 — CONTROL SYSTEMS

(Regulations 2021)

Time : Three hours

Maximum : 100 marks

Answer ALL questions.

PART A — (10 × 2 = 20 marks)

1. Find the closed loop transfer function for the system shown in Fig. Q-1.

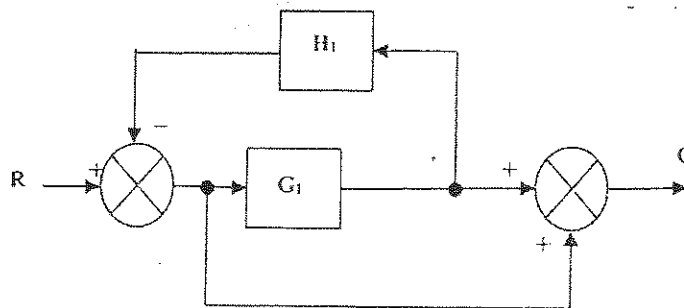

Fig. Q-1

2. Write the Mason's gain formula to determine overall closed loop system function using signal flow graph.
3. Find the damping factor, ζ and the natural frequency, ω_n for the unity feedback system with open loop transfer function, $G(S) = \frac{10}{s(s+1)}$.
4. What is the steady state error for a Type-0 system when the input is $r(t) = \frac{t^2}{2}$?
5. Relate bandwidth of a system to damping ratio ζ of the system and write the expression.

6. When drawing the Bode plot for an unity feedback system with open loop transfer function $G(S) = \frac{5}{s(1 + 0.5s)}$, will the phase plot cross the -180° line?
7. If the poles of a second order system are located at $s = -1$ and $s = -2$, indicate the state equation in 'diagonalized form'.
8. What do you mean by the term observability of a system with regard to state space model of the system?
9. Sketch the frequency response of a lag-lead compensator.
10. What is the effect of integral control on the performance of a system?

PART B — (5 × 13 = 65 marks)

11. (a) (i) The block diagram of a closed loop control system is shown in Fig Q-11(a)(i), determine the overall transfer $\frac{C}{R}$ using block diagram reduction technique. (8)

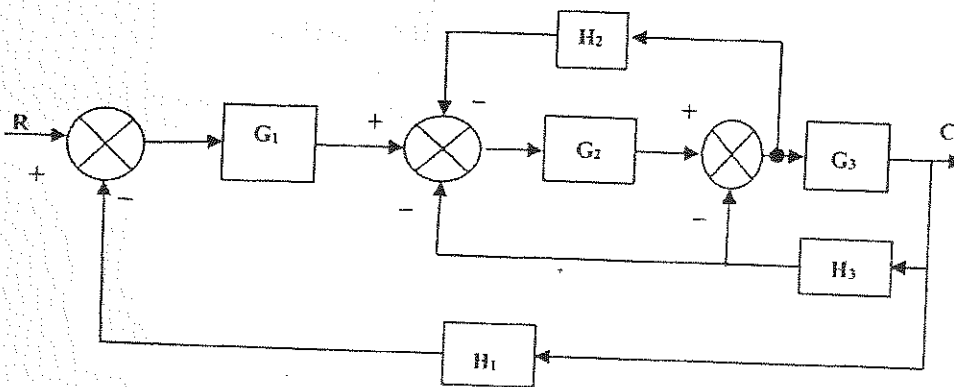

Fig Q-11(a)(i)

- (ii) Determine the transfer function $\frac{E_o(s)}{E_i(s)}$ for the electric circuit shown in Fig. Q 11(a)(ii). (5)

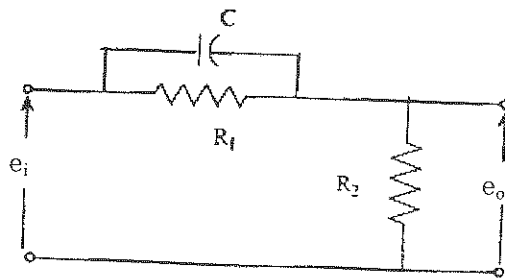

Fig. Q.11(a)(ii)

Or

(b) (i)

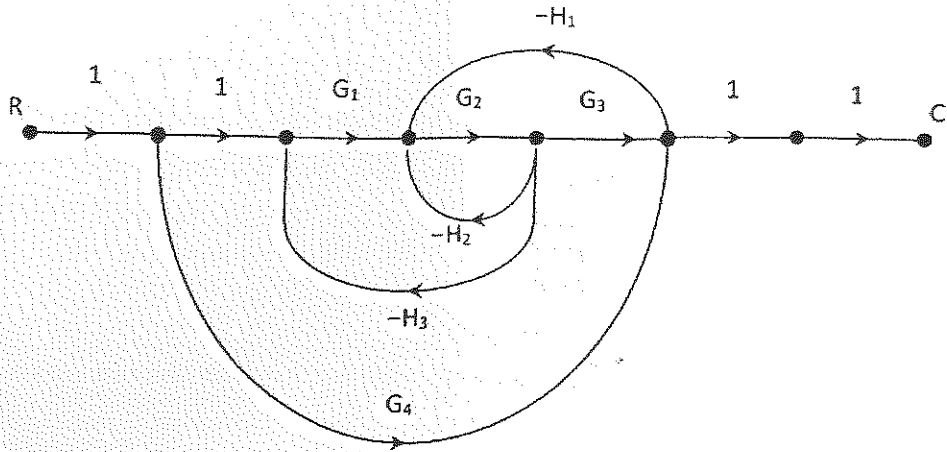

Fig.Q. 11(b)(i)

For the closed loop system shown as signal flow graph in Fig Q.11(b)-(i), deduce the overall transfer function using Mason's Gain Formula. (7)

- (ii) Write down the differential equations that govern the mechanical system shown in Fig. Q.11(b)(ii), and obtain the transfer function $\frac{X_2(s)}{F(s)}$. (6)

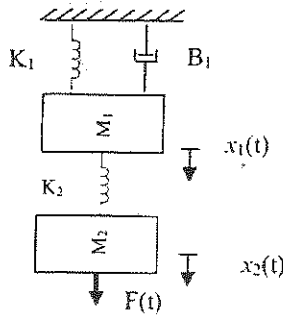

Fig. Q11(b)(ii)

12. (a) (i) Derive the expression for unit step response of an under damped second order system given by the transfer function $\frac{\theta(s)}{T(s)} = \frac{K\omega_n^2}{s^2 + 2\zeta\omega_n s + \omega_n^2}$ where ω_n is natural frequency and ζ , the damping coefficient. (6)
- (ii) A unity feedback system is characterized by the open loop transfer function $G(s) = \frac{10}{s(s+2)}$. Determine the response of this system for a unit step input. Evaluate the maximum overshoot and the corresponding time for maximum overshoot. (7)

Or

(b) (i) A feedback control system has $G(s) = \frac{K(s+40)}{s(s+10)}$ and the sensor transfer function is $H(s) = \frac{1}{(s+20)}$. Find the gain K which results in marginal stability. Determine the oscillation frequency. (6)

(ii) A unity feedback system has an open loop transfer function given by $G(s) = \frac{k}{s(s+3)(s^2+2s+2)}$. Sketch the root locus plot of this system indicating the

- (1) real axis segments
- (2) point of intersection of root locus on the imaginary axis,
- (3) breakaway points. (7)

13. (a) (i) The open loop transfer function of a unity feedback system is given by $G(s) = \frac{5(1+2s)}{s(1+4s)(1+0.25s)}$. Sketch the Bode plot of this system and obtain the gain margin and phase margin. (8)

(ii) Determine the frequency domain specifications of a second order system whose closed loop transfer function is given by, $\frac{C(s)}{R(s)} = \frac{64}{s^2 + 12s + 64}$. (5)

Or

(b) (i) The open loop transfer function of a unity feedback system is given by $G(s) = \frac{1}{s(1+0.1s)(1+0.01s)}$. Sketch the polar plot of this system and obtain the gain margin and phase margin. (8)

(ii) At what frequency the polar plot of the system with transfer function $G(s) = \frac{1}{(j\omega)(1+j\omega\tau_1)(1+j\omega\tau_2)}$ will cross the -180° axis. (5)

14. (a) (i) Construct the state model in Jordan canonical form, for the system whose closed loop transfer function is $\frac{C(s)}{U(s)} = \frac{10}{s(s+1)(s+3)}$. (6)

(ii) Given that the state model of the system as follows :

$$\begin{bmatrix} \dot{x}_1 \\ \dot{x}_2 \\ \dot{x}_3 \end{bmatrix} = \begin{bmatrix} 0 & 1 & 0 \\ 0 & 0 & 1 \\ -6 & -11 & -6 \end{bmatrix} \begin{bmatrix} x_1 \\ x_2 \\ x_3 \end{bmatrix} + \begin{bmatrix} 0 \\ 0 \\ 1 \end{bmatrix} u \quad \text{and} \quad y = [20 \quad 9 \quad 1] \begin{bmatrix} x_1 \\ x_2 \\ x_3 \end{bmatrix}$$

Check whether this system is completely state controllable and observable? (7)

Or

- (b) (i) Construct the state model in phase variable form, for the system whose closed loop transfer function is $\frac{C(s)}{U(s)} = \frac{10}{s(s+1)(s+3)}$. (7)
- (ii) If a second order system is given by the transfer function, $\frac{Y(s)}{U(s)} = \frac{10}{s^2 + 4s + 3}$ find the Eigen values for this system. (6)
15. (a) (i) Discuss in detail about the step by step procedure to design a lag compensator using Root Locus. (6)
- (ii) The open loop transfer function of the uncompensated system is $G(s) = \frac{5}{s(s+2)}$. Design a suitable compensator for the system so that the static velocity error constant $K_v = 20 \text{ sec}^{-1}$ and the phase margin is at least 55° and the gain margin is at least 12 dB. (7)

Or

- (b) (i) Discuss in detail the procedure to design a lead compensator using Bode plot. (6)
- (ii) For the unity feedback system with open loop transfer function $G(s) = \frac{1}{s(s+1)}$, it is desired to obtain the phase margin greater than 45° and steady state error less than 0.1 for a unit ramp input. Design a lead compensator that meets the given specifications using Bode plot. (7)

PART C — (1 × 15 = 15 marks)

16. (a) The Fig. Q16(a)(i) shows a system employing proportional plus error rate control. Determine the value of error rate factor K_e so that the damping ratio is 0.5. Determine the value of maximum overshoot for unit step input and the steady state error for unit ramp input, with and without error rate control.

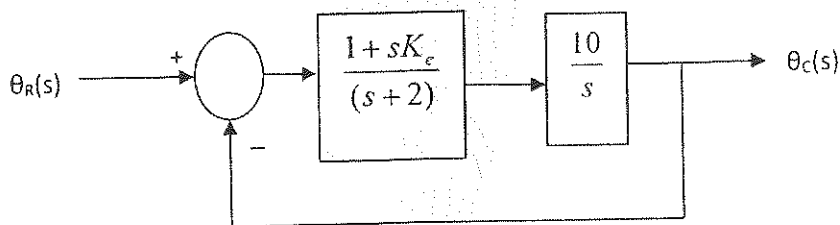

Fig. Q.16(a)(i)

Or

- (b) (i) The state model of a system is given as,

$$\begin{bmatrix} \dot{x}_1 \\ \dot{x}_2 \end{bmatrix} = \begin{bmatrix} 0 & 11 \\ -12 & -7 \end{bmatrix} \begin{bmatrix} x_1 \\ x_2 \end{bmatrix} + \begin{bmatrix} 0 \\ 1 \end{bmatrix} u(t) \text{ and } y = [-1 \quad -4] \begin{bmatrix} x_1 \\ x_2 \end{bmatrix} + u(t).$$

Determine the state transition matrix. Assuming initial conditions as zero, find the transfer function for the system. (8)

- (ii) For the state model given in Q.16(b)(i) obtain the unit step response assuming initial conditions as, $\begin{bmatrix} x_1(0) \\ x_2(0) \end{bmatrix} = \begin{bmatrix} 1 \\ 0 \end{bmatrix}$. (7)