

Reg. No. : 

--	--	--	--	--	--	--	--	--	--	--	--	--	--	--	--	--	--	--

**Question Paper Code : 72140**

12/05/17 RW

B.E./B.Tech. DEGREE EXAMINATION, APRIL/MAY 2017.

Third/Fourth Semester

Mechanical Engineering

ME 6401 — KINEMATICS OF MACHINERY

(Common to Mechanical Engineering (Sandwich)/Mechatronics Engineering)

(Regulations 2013)

Time : Three hours

Maximum : 100 marks

Answer ALL questions.

PART A — (10 × 2 = 20 marks)

1. What type of kinematic pair exists between human shoulder and arm based on nature of contact and nature of relative motion?
2. Sketch and define Transmission angle of a four bar mechanism.
3. Find the resultant acceleration of an 80mm radius crank rotating at a constant angular velocity of 10 rad/s, at the crank – pin position.
4. Illustrate the instantaneous centres of a typical four bar mechanism.
5. Which type of cam follower motion is preferred for high speed engines? Why?
6. Give any two applications of cam mechanism in IC engines.
7. State law of gearing.
8. What type of gear arrangement is used to traverse the carriage in lathe machine?
9. What kind of friction acts between the tyre and road in an automobile?
10. State the functional difference between a clutch and a brake.

Assuming that the load rotates with the screw, determine the

- (i) Ratio of torques required to raise and lower the load
- (ii) Efficiency of the machine.

(13)

Or

- (b) A single plate clutch transmits 25 kw at 900 rpm. The maximum pressure intensity between the plates is 85 kN/m<sup>2</sup>. The outer diameter of the plate is 360 mm. Both the sides of the plate are effective and the coefficient of friction is 0.25. Determine the
- (i) Inner radius of the plate
  - (ii) Axial force to engage the clutch.

(13)

PART C — (1 × 15 = 15 marks)

16. (a) Figure 16 (a) shows a mechanical press used to exert large forces to insert a small part into a larger one. Draw a kinematic diagram, using the end of the handle as a point of interest. Also compute the degrees of freedom.

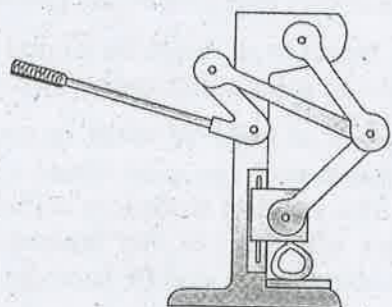

Figure 16(a)

Or

- (b) A cam is to be used for a platform that will repeatedly lift boxes from a lower conveyor to an upper conveyor. This machine is shown in Figure 16(b). Plot a displacement diagram and determine the required speed of the cam when the follower motion sequence is as follows:
- (i) Rise 40mm in 1.2 s.
  - (ii) Dwell for 0.3 s.
  - (iii) Fall 20 mm in 0.9 s.
  - (iv) Dwell 0.6 s.
  - (v) Fall 20 mm in 0.9 s.

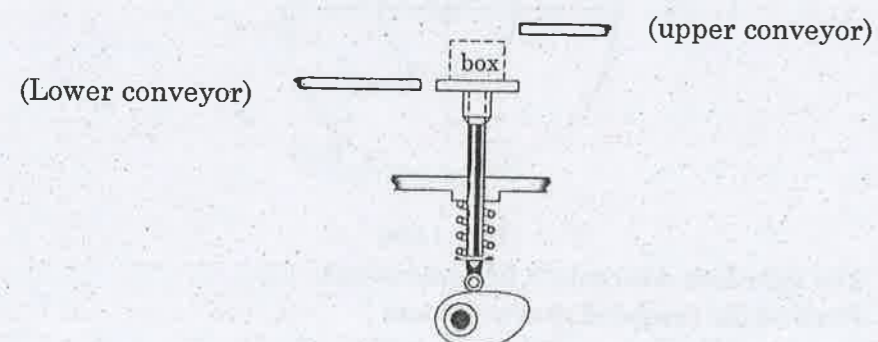

Fig. 16(b)

PART B — (5 × 13 = 65 marks)

11. (a) What is a kinematic inversion? Discuss any three applications of inversions of slider crank mechanism with suitable sketches. (13)

Or

- (b) (i) Find the degrees of freedom for the mechanisms shown in Fig 11(b) (i). (7)

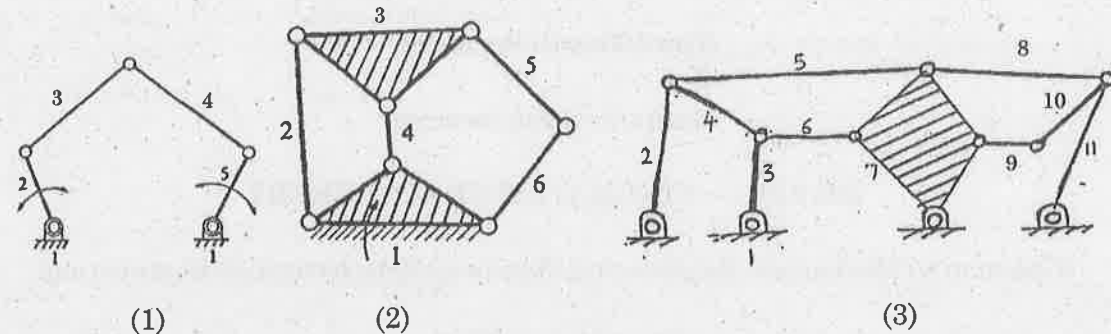

Fig. 11 (b) (i).

- (ii) Explain mechanical advantage and transmission angle related to four bar mechanism. (6)
12. (a) An engine mechanism is shown in Fig. 12 (a). The crank CB = 200 mm and the connecting rod BA = 600 mm. In the position shown, the crankshaft has a speed of 50 rad/s and an angular acceleration of 800 rad/s<sup>2</sup>. Find: (i) angular velocity of AB and (ii) angular acceleration of AB. (13)

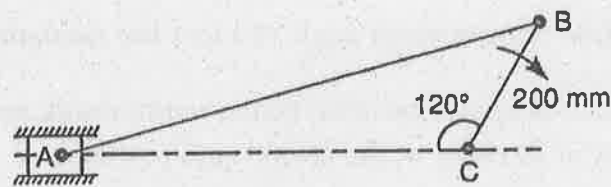

Fig. 12(a)

Or

- (b) Locate all the instantaneous centres of the slider crank mechanism as shown in Fig. 12 (b). The lengths of crank OB and connecting rod AB are 100 mm and 400 mm respectively. If the crank rotates clockwise with an angular velocity of 10 rad/s, find: (i) Velocity of the slider A, and (ii) Angular velocity of the connecting rod AB. (13)

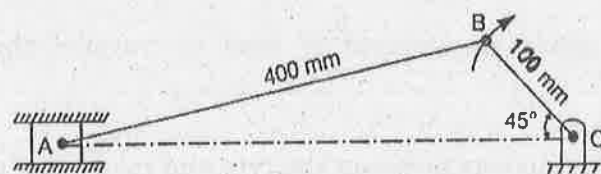

Fig. 12(b)

13. (a) Draw the profile of a cam operating a knife edge follower having a lift of 30 mm. The cam raises the follower with SHM for 150° of the rotation followed by a period of dwell for 60°. The follower descends for the next 100° rotation of the cam with uniform velocity, again followed by a dwell period. The cam rotates at a uniform velocity of 120 rpm and has a least radius of 20 mm. What will be the maximum velocity and acceleration of the follower during the lift and the return? (13)

Or

- (b) In a symmetrical tangent cam operating a roller follower, the least radius of the cam is 30 mm and roller radius is 17.5 mm. The angle of ascent is 75° and the total lift is 17.5 mm. The speed of the cam shaft is 600 r.p.m. Calculate: (i) The principal dimensions of the cam; (ii) the accelerations of the follower at the beginning of the lift, where straight flank merges into the circular nose and at the apex of the circular nose; (iii) Draw the profile of the cam. Assume that there is no dwell between ascent and descent. (13)

14. (a) The following data relate to a pair of 20° involute gears in mesh:

Module = 6 mm, Number of teeth on pinion = 17, Number of teeth on gear = 49; Addenda on pinion and gear wheel = 1 module.

Find: (i) The number of pairs of teeth in contact (ii) The angle turned through by the pinion and the gear wheel when one pair of teeth is in contact, and (iii) The ratio of sliding to rolling motion when the tip of a tooth on the larger wheel (1) is just making contact, (2) is just leaving contact with its mating tooth, and (3) is at the pitch point. (13)

Or

- (b) An epicyclic gear consists of three gears A, B and C as shown in Fig. 14 (b). The gear A has 72 internal teeth and gear C has 32 external teeth. The gear B meshes with both A and C and is carried on an arm EF which rotates about the centre of A at 18 r.p.m.. If the gear A is fixed, determine the speed of gears B and C. (13)

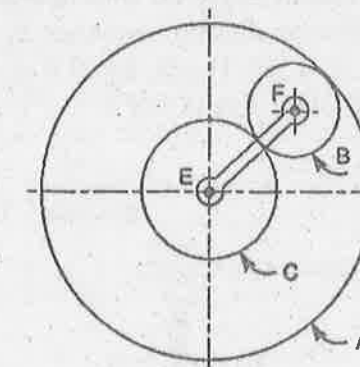

Fig. 14(b)

15. (a) The following data relate to a screw jack:
- Pitch of the threaded screw = 8 mm
  - Diameter of the threaded screw = 40 mm
  - Coefficient of friction between screw and nut = 0.1
  - Load = 20kN