



Reg. No. :

--	--	--	--	--	--	--	--	--	--	--	--	--	--	--	--	--	--	--	--

Question Paper Code : 90204

B.E./B.Tech. DEGREE EXAMINATIONS, NOVEMBER/DECEMBER 2019

Fifth Semester

Electrical and Electronics Engineering

EE 8501 – POWER SYSTEM ANALYSIS

(Regulations 2017)

Time : Three Hours

Maximum : 100 Marks

Answer ALL questions

PART – A

(10×2=20 Marks)

1. What are the needs for power system planning ?
2. Define bus incidence matrix.
3. What is slack bus ?
4. What are the advantages of N-R method ?
5. What do you mean by symmetrical faults ?
6. What is the need for short circuit analysis ?
7. Define positive sequence impedance.
8. Name the various unsymmetrical faults in a power system.
9. Define steady state stability.
10. State equal area criterion.



PART - B

(5×13=65 Marks)

11. a) Calculate the per unit quantities of the given one-line diagram. T_2 is composed of three single phase units each rated at 30 MVA, 66/10 kV with 5% reactance. Take generator rating as base.

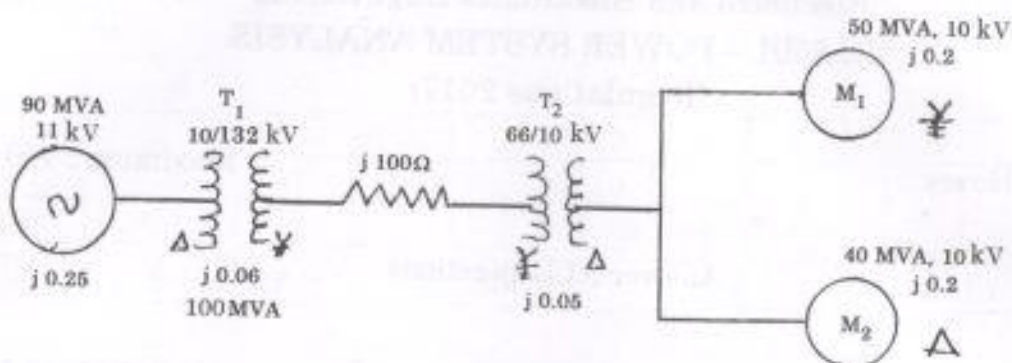

Figure 11(a)

(OR)

- b) Determine the bus admittance matrix for the given power system.

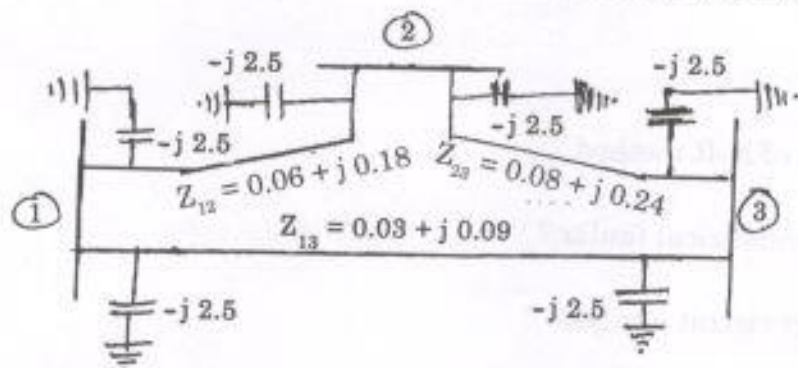

Figure 11(b)



12. a) Derive load flow algorithm using Gauss – Seidel method with flow chart and discuss the advantages of the method.

(OR)

- b) The one-line diagram of a simple three bus power system with generators at bus 1 and 2. The magnitude of voltage at bus 1 and 2 are adjusted to 1.06 and 1.05 p.u. The scheduled load at bus 2 is marked. Line impedances are marked to per unit on a 100 MVA base and the line charging is neglected. Solve by N-R method.

Bus Number	Type	Generator (p.u.)		Load (p.u.)		Voltage (p.u.)	Angle (deg)	Reactive Power Limit	
		P_g	Q_g	P_d	Q_d			Q_{min}	Q_{max}
1	Slack	0	0	0	0	1.06	0	-	-
2	PQ	0	0	6	2.5	0	0	-	-
3	PV	2	0	0	0	1.05	0	0.1	2.5

Element	Bus Code	Self-impedance (Ω)
1	1-2	$0.01 + j0.05$
2	1-3	$0.07 + j0.2$
3	2-3	$0.02 + j0.15$

13. a) Describe the construction of Bus impedance matrix (Z_{Bus}) using building algorithm for lines without mutual coupling.

(OR)

- b) A four bus sample power system is shown in Figure 13(b). Perform the short circuit analysis for a three phase fault on bus 4 are given below.

G_1 : 11.2 kV, 100 MVA, $X = 0.08$ p.u.

G_2 : 11.2 kV, 100 MVA, $X = 0.08$ p.u.

T_1 : 11/110 kV, 100 MVA, $X = 0.06$ p.u.

T_2 : 11/110 kV, 100 MVA, $X = 0.06$ p.u.

Assume pre fault voltages 1.0 p.u. and pre fault currents to be zero.

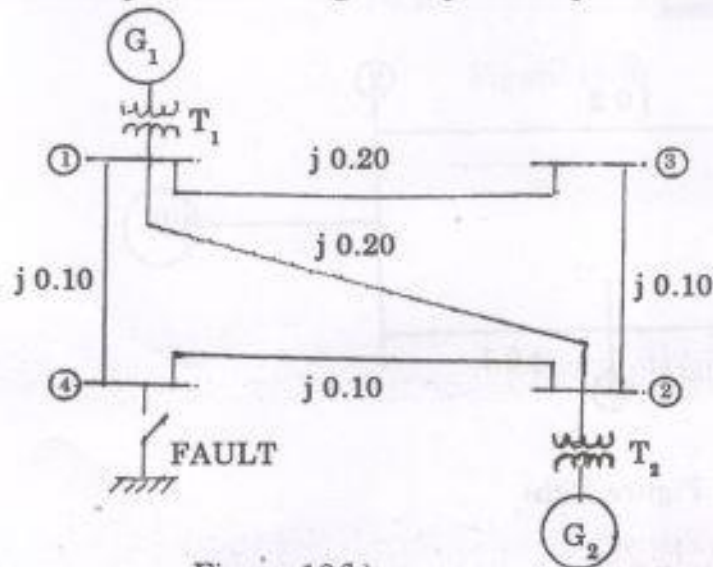

Figure 13(b)



14. a) Derive the expression for fault current in line-to-line fault on an unloaded generator in terms of symmetrical components.

(OR)

- b) A 50 MVA, 11 kV synchronous generator has a sub-transient reactance of 20%. The generator supplies two motors over a transmission line with transformers at both ends as shown in Figure 14(b). The motors have rated inputs of 30 and 15 MVA, both 10 kV, with 25% sub-transient reactance. The three phase transformers are both rated 60 MVA, 10.8/121 kV, with leakage reactance of 10% each. Current limiting reactors of 2.5 ohms each connected in the neutral of the generator and the motor number 2. The zero sequence reactance of the transmission line is 300 ohms. The series reactance of the line is 100 ohms. Draw the positive, negative and zero sequence networks.

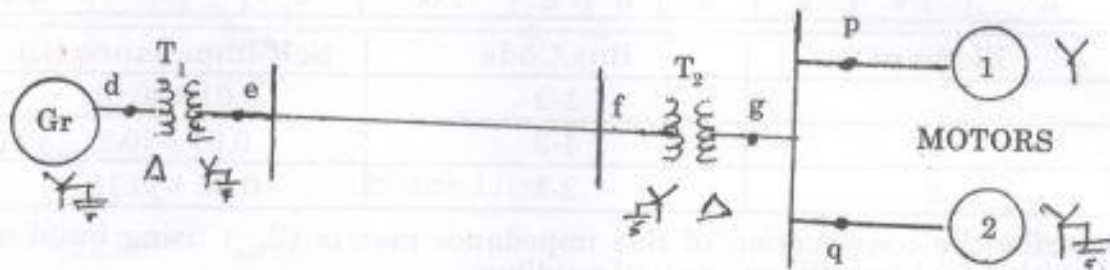

Figure 14(b)

15. a) Derive swing equation used for stability studies in power system.

(OR)

- b) A single line diagram of a system is shown in Figure 15(b). All the values are in per unit on a common base. The power delivered into bus 2 is 1.0 p.u. at 0.80 power factor lagging. Obtain the power angle equation and the swing equation for the system. Neglect all losses.

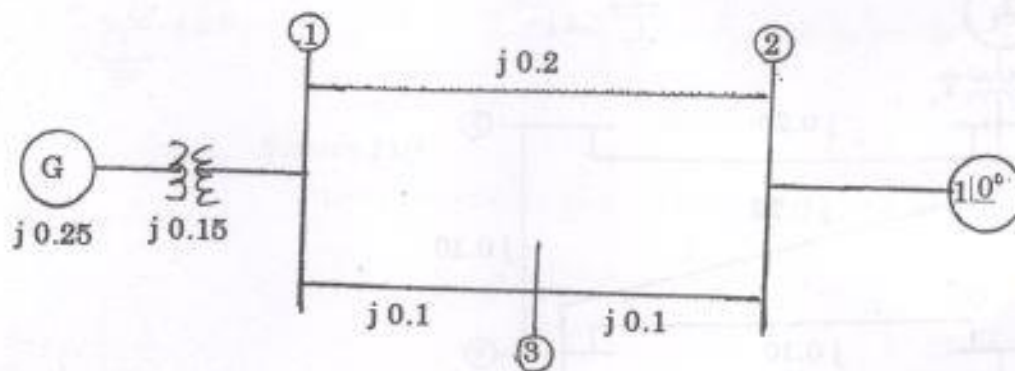

Figure 15(b)



PART - C

(1×15=15 Marks)

16. a) Two alternators are operating in parallel and supplying a synchronous motor which is receiving 60 MW power at 0.8 power factor lagging at 6.0 kV. Single line diagram for this system is given in Figure 16(a). Data are given below. Compute the fault current when a single line to ground fault occurs at the middle of the line through a fault resistance of 4.033 ohm.

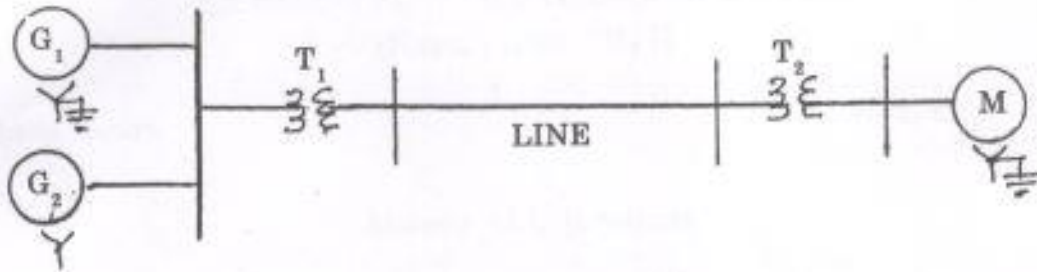

Figure 16(a)

(OR)

- b) Find the critical clearing angle for the system shown in Figure 16(b) for a 3Φ fault at the point P. The generator is delivering 1 p.u. power under balanced conditions.

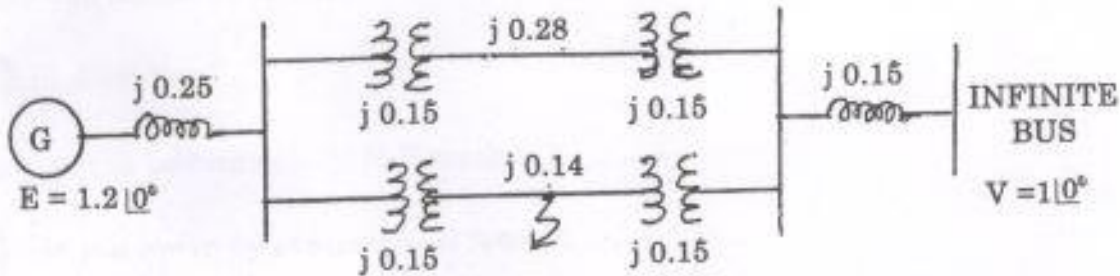

Figure 16(b)