

15/12/18
 AN

Reg. No. :

--	--	--	--	--	--	--	--	--	--	--

- (b) Find the loop transmission $L(s)$ and the characteristic equation for the positive-feedback circuit shown below. Sketch a root-locus diagram for varying K , and find the value of K that results in a maximally flat response and the value of K that makes the circuit oscillate. Assume that the amplifier has frequency-independent gain, infinite input impedance, and zero output impedance.

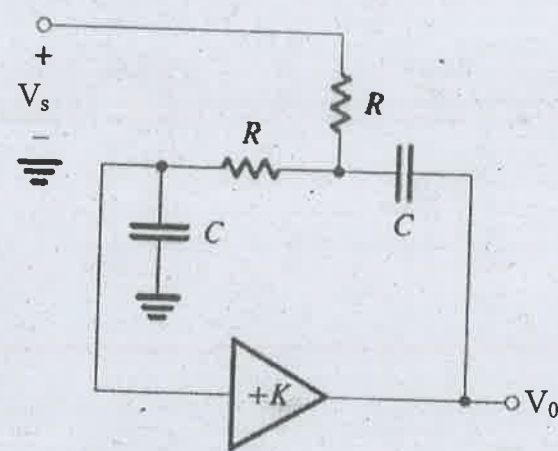

Question Paper Code : 20411

B.E./B.Tech. DEGREE EXAMINATION, NOVEMBER/DECEMBER 2018.

Fourth Semester

Electronics and Communication Engineering

EC 6401 — ELECTRONIC CIRCUIT — II

(Regulations 2013)

(Common to : PTEC 6401 — Electronic Circuit — II for B.E. (Part-Time)
 Third Semester — Electronics and Communication Engineering — Regulations — 2014)

Time : Three hours

Maximum : 100 marks

Answer ALL questions.

PART A — (10 × 2 = 20 marks)

1. Why negative feedback is used in amplifiers?
2. Draw the general structure of a feedback amplifier.
3. State Barkhausen criterion.
4. Draw the diagram depicting the basic structure of a sinusoidal oscillator.
5. What are the requirements of a tuned amplifier?
6. Draw the frequency response of the stagger and synchronous tuned amplifiers.
7. What is the purpose of triggering in bistable multivibrators?
8. What are multivibrator circuits?
9. Give any two applications of pulse transformers.
10. Why linearity correction is required in time base generation?

PART B — (5 × 13 = 65 marks)

11. (a) Discuss on the impact of negative feedback amplifiers on Gain, Gain Sensitivity and Bandwidth.

Or

- (b) For the given circuit, assuming that the op amp has infinite input resistance and zero output resistance, find (i) an expression for the feedback factor β , (ii) the condition under which the closed-loop gain is almost entirely determined by the feedback network. (iii) If the open-loop gain, $A = 10^4$. Find R_2/R_1 to obtain a closed-loop gain of $A_f = 10$.

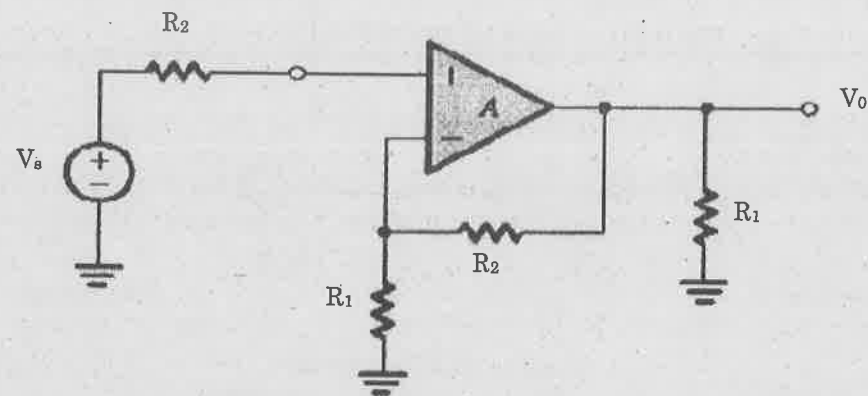

12. (a) With a neat diagram, explain the operation of the Colpitts oscillator. Also derive an expression for the condition and frequency of oscillation.

Or

- (b) Give the equivalent circuit of the crystal and explain the principle behind crystal oscillator. With a neat diagram, explain the operation of the Pierce crystal oscillator.

13. (a) With required diagrams, analyze the single tuned amplifier with the small signal AC equivalent circuit and derive the expressions for its gain and bandwidth.

Or

- (b) Using AC equivalent circuit analysis, derive the expression for the gain of a double tuned amplifier.

14. (a) Calculate (i) the rise time and (ii) the time required for the collector current to rise to 10% of I_{CS} for the circuit shown below. Assume $f_T = 10$ MHz and $h_{FE} = 100$.

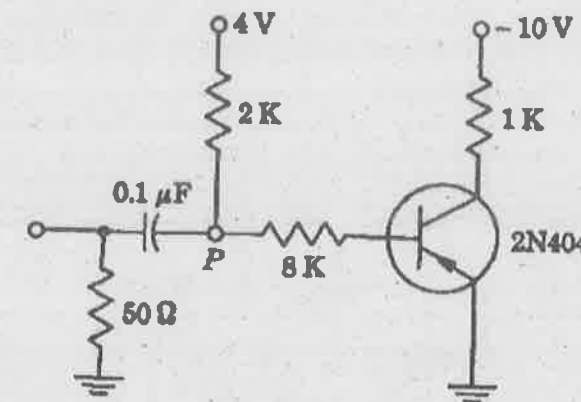

Or

- (b) With relevant diagrams, explain how a standardized pulse can be generated using mono stable multivibrator?
15. (a) With necessary diagram, explain the equivalent circuit of a pulse transformer. A pulse transformer has the following parameters : $L = 5$ mH, $\sigma = 40$, μH , $C = 50$ pF, $R_1 = 200$ Ω , $R_2 = 2$ k Ω , $n = 1$. Find the response to a 2 μs -10V pulse.

Or

- (b) Explain the working principle of blocking oscillators. With neat diagram, explain the operation of a monostable blocking oscillator with base timing.

PART C — (1 × 15 = 15 marks)

16. (a) Derive the expression for frequency of oscillation for the given circuit. For $R = 10$ K Ω and $C = 16$ nF, find the frequency of oscillation and the minimum required R_f value to set the oscillations.

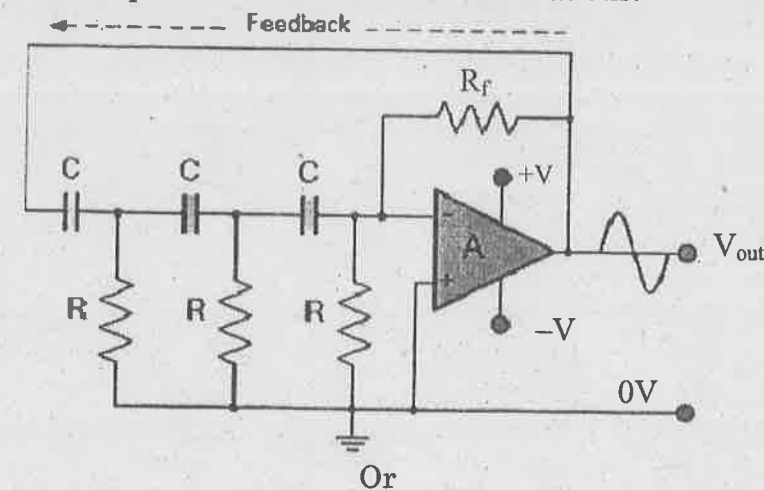

Or